

TRINUS[®]

QUICK START GUIDE



STEP 1 : ASSEMBLY

1. It takes about 30-45 minutes to go through the assembly manual and assemble your Trinus, depending on your experience with 3D printers.
2. Our manual is best paired with our video tutorials and with the unofficial guide put together by Trinus users. Trinus3D.com/tutorials and Trinus3D.com/guide

Some SD-cards shipped blank in order to speed up fulfillment. Please visit Trinus3D.com/sdcard for the contents.

STEP 2: POWER ON



▲ Make sure that all cables are connected.



▲ Connect the power cable: A beep will confirm that the machine is ready.



▲ Check the light at the top of the machine: If white, the print head may be missing or not properly attached. If the light is cyan, you are ready to go.

STEP 3: YOUR FIRST PRINT

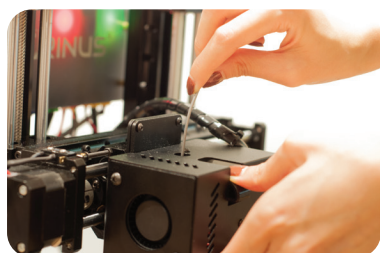

- ▲
1. To understand how to load or change your filament correctly, please watch: Trinus3D.com/filamentguide
 2. Cut the tip of your filament at a 45° angle as described in the video.
 3. Press down on the print head lever, then insert the filament into the feeder. Make sure to push it down far enough.

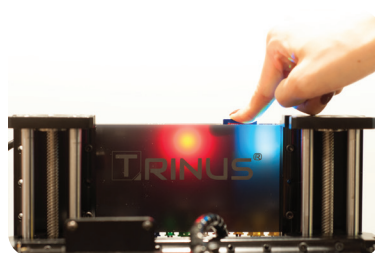

▲ Your SD card contains an "autoprint" file: It is a test model.

Insert the SD card into the slot: You will hear a double beep and the main light will change to blinking red. The nozzle will heat up. Once it reaches around 200 °C, your print will start. It will be ready in 2-3 hours.



▲ Seconds before the print starts the extruder will push out some filament. Use tweezers to remove it before the head moves to the printing position.

TRINUS[®]

QUICK START GUIDE



STEP 4: INSTALL SLICER SOFTWARE



Please download Pango and watch our Pango tutorial here:
Trinus3D.com/Pango

OPTIONAL: Z-AXIS CALIBRATION

For the perfect print, you may need to calibrate your Z axis. This means adjusting the distance between the tip of the nozzle and your print bed. You want that gap to be about as thick as a piece of paper. Too close and you'll damage your print bed. Too far and your print won't settle.

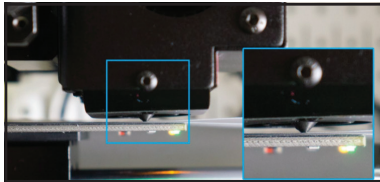

▲ CORRECT DISTANCE

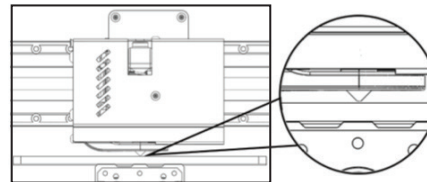

▲ CORRECT DISTANCE

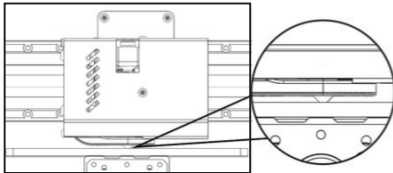
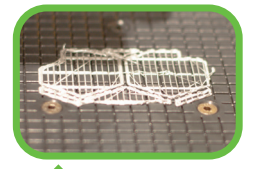

▲ TOO LOW

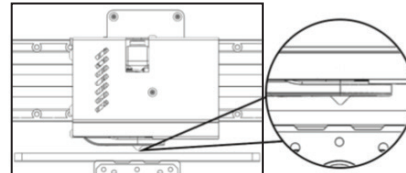

▲ TOO HIGH



If you need to calibrate, connect your Trinus to your Mac or PC with the provided PCB cable and open up your console via Pango as pictured.

Adjust your Z axis in increments of 0.1 for precision. The higher the Z offset, the closer your nozzle is to the print bed. For example, 0.2 is closer than 0.1

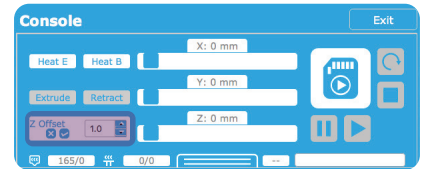
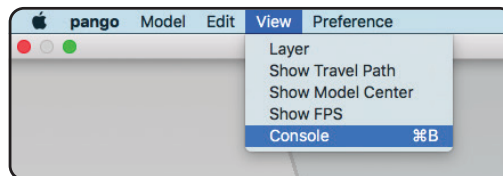

SERVICE & SUPPORT

These first steps should get you a good start with your Trinus.

For more information, Kodama has a vibrant community full of friendly, helpful people eager to answer questions and share their knowledge. They can be found at www.kodamaforum.com and in our Facebook group www.facebook.com/groups/Trinus3D.

For questions regarding your order or to report a problem, please visit <http://support.kodama3d.com>

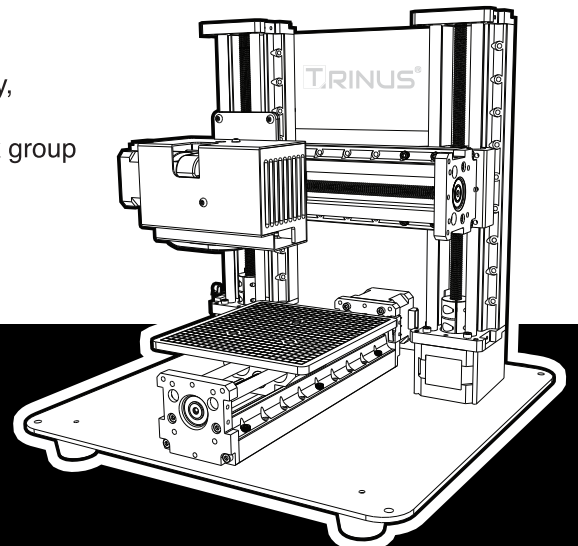

@trinus_3dprinter

/kodama3d

@trinus3d